

MGA-53589

50MHz to 6GHz High Linear Amplifier



Data Sheet

Description

Avago Technologies's MGA-53589 is a highly dynamic range low noise amplifier MMIC, housed in a SOT-89 standard plastic package.

MGA-53589 is especially ideal for Cellular/PCS/W-CDMA basestation, wireless LAN, WLL and other systems in the 50MHz to 6GHz frequency range applications. With high IP3 and low noise figure, the MGA-53589 may be utilized as a driver amplifier in the transmit chain and as a second stage LNA in the receive chain.

MGA-53589 is a versatile component and allows circuit designers to put suitable external matching elements to suit its intended application such as max OIP3, lowest NF, highest return loss and etc.

Pin connections and Package Marking

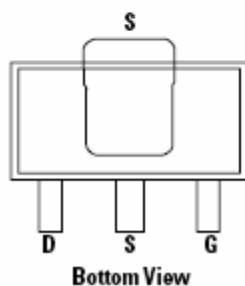
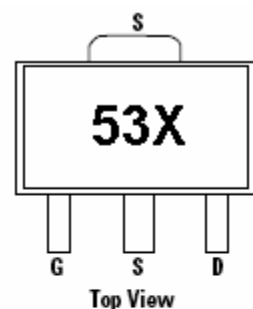

Note:
Top View : Package marking provides orientation and identification
"53" = Device Code
"X" = Date Code character identifies month of manufacturing

Features

- Lead-free Option Available
- Very high linearity at low DC bias power^[1]
- Low noise figure
- High OIP3
- Advanced enhancement mode PHEMT Technology
- Excellent uniformity in product specification
- SOT-89 standard package

Specifications

At 1.9GHz, V_{dd}=5V, I_{dd}=52mA (typ) @ 25 °C

- OIP3 = 37dBm
- Noise Figure = 1.66dB
- Gain = 15.8 dB
- OP1dB = 18.2 dBm
- S11 = -14.4 dB, S22 = -15.7 dB

Application

- Base station radio card
- High linearity LNA for base stations, WLL, WLAN and other applications in the 50MHz to 6GHz range.

Note:

1. The MGA-53589 has a superior LFOM of 19dB. Linearity Figure of Merit (LFOM) is essentially OIP3 minus OP1dB. There are few devices in the market that can match its combination of high linearity and low noise figure at the low DC bias power of 5V/52mA.



Attention: Observe precautions for handling electrostatic sensitive devices.
ESD Machine Model = 40 V
ESD Human Body Model = 250 V
Refer to Avago Application Note A004R: Electrostatic Discharge, Damage and Control.

MGA-53589 Absolute Maximum Ratings^[1]

Symbol	Parameter	Units	Absolute Maximum
V _{in}	Max input voltage	V	0.8
V _d	Supply Voltage(I _d =52mA)	V	5.5
P _d	Power Dissipation ^[2]	mW	400
P _{in}	CW RF Input Power	dBm	13
T _j	Junction Temperature	°C	150
T _{stg}	Storage Temperature	°C	-65 to 150

Thermal Resistance^[3]
(V_d=5.0V) θ_{jc} = 62.5°C/W

Notes:

1. Operation of this device in excess of any of these limits may cause permanent damage.
2. Source lead temperature is 25°C. Derate 16mW/°C for T_L > 98°C
3. Thermal resistance measured using 150°C Infra-Red Microscopy Technique.

MGA-53589 Electrical Specification

T_C = 25 °C, Z₀=50Ω, V_d=5V, unless noted

Symbol	Parameter and Test Condition	Frequency	Units	Min.	Typ.	Max.	Stdev ^[3]
I _d	Current Drawn	N/A	mA	40	52	70	0.001
NF	Noise Figure	0.9GHz ₍₁₎	dB	-	1.24	-	-
		1.9GHz ₍₁₎		-	1.66	2	0.02
		2.4GHz ₍₁₎		-	1.61	-	-
Gain	Gain	0.9GHz ₍₁₎	dB	-	18.2	-	-
		1.9GHz ₍₁₎		14	15.8	17	0.07
		2.4GHz ₍₁₎		-	15.3	-	-
OIP3	Output Third Order Intercept Point(2)	0.9GHz ₍₁₎	dBm	-	36.8	-	-
		1.9GHz ₍₁₎		34	37	-	0.66
		2.4GHz ₍₁₎		-	37.2	-	-
OP1dB	Output Power at 1dB Gain Compression	0.9GHz ₍₁₎	dBm	-	18.6	-	-
		1.9GHz ₍₁₎		16.5	18.2	-	0.12
		2.4GHz ₍₁₎		-	17.6	-	-
PAE	Power Added Efficiency at P1dB	0.9GHz ₍₁₎	%	-	24.7	-	-
		1.9GHz ₍₁₎		-	27.3	-	0.21
		2.4GHz ₍₁₎		-	22.7	-	-
RL _{in}	Input Return Loss	0.9GHz ₍₁₎	dB	-	13.6	-	-
		1.9GHz ₍₁₎		-	14.4	-	0.29
		2.4GHz ₍₁₎		-	11.6	-	-
RL _{out}	Output Return Loss	0.9GHz ₍₁₎	dB	-	20.3	-	-
		1.9GHz ₍₁₎		-	15.7	-	0.31
		2.4GHz ₍₁₎		-	14.1	-	-
ISOL	Isolation	0.9GHz ₍₁₎	dB	-	22.1	-	-
		1.9GHz ₍₁₎		-	22.4	-	0.09
		2.4GHz ₍₁₎		-	22.3	-	-

Note :

1. Measurements obtained from a test circuit described in Figure 6. Input and output matching components are tuned for consistent OIP3; while keeping VSWR better than 2:1. Data obtained are minus board losses.
2. I) Output power level and frequency of two fundamental tones at 0.9GHz; F1 & F2 = -0.38dB; F1=0.905GHz and F2=0.915GHz
II) Output power level and frequency of two fundamental tones at 1.9GHz; F1 & F2 = 5.49dB; F1=1.905GHz and F2=1.915GHz
III) Output power level and frequency of two fundamental tones at 2.4GHz; F1 & F2 = 5dB; F1=2.405GHz and F2=2.415GHz
3. Standard deviation data are based on at least 500 pieces samples size taken from 2 wafer lots. Future wafers allocated to this product may have nominal values anywhere between the upper and lower specification limits.

MGA-53589 Consistency Distribution Chart at 1900MHz [1,2]

$T_C = 25\text{ }^\circ\text{C}$, $V_d=5\text{V}$ (in production test board tuned for optimum OIP3)

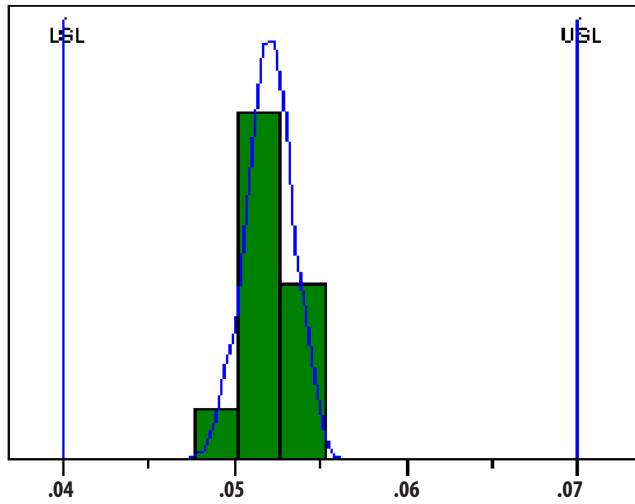

Figure 1. Idd Distribution

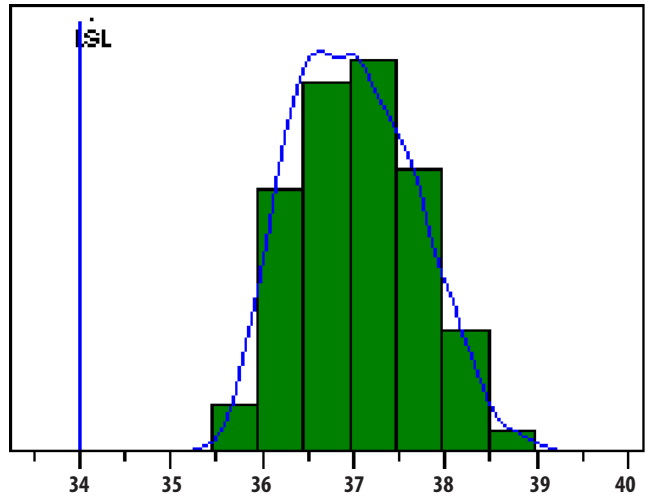

Figure 2. OIP3 Distribution

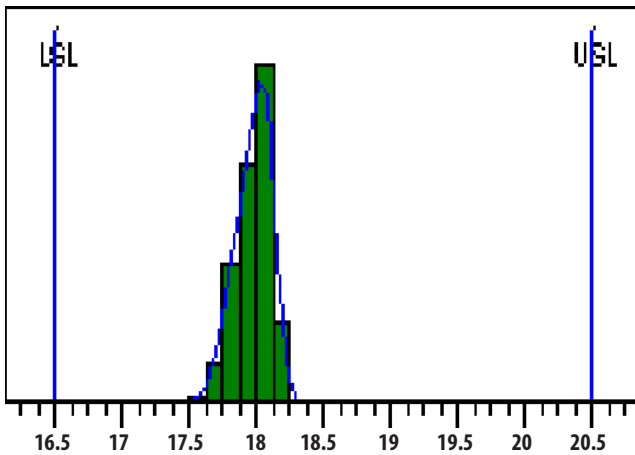

Figure 3. OP1dB

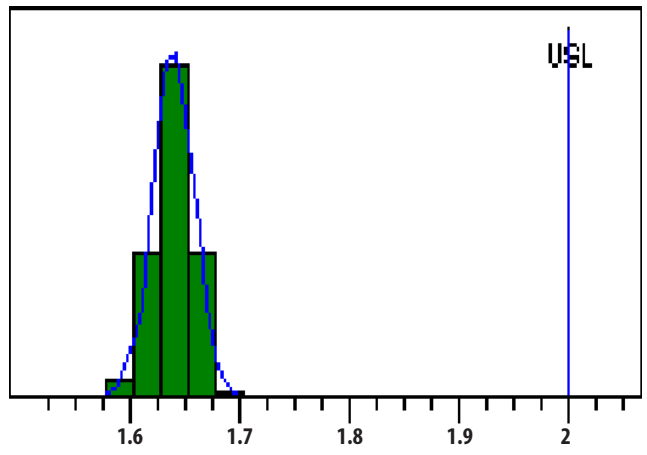

Figure 4. NF

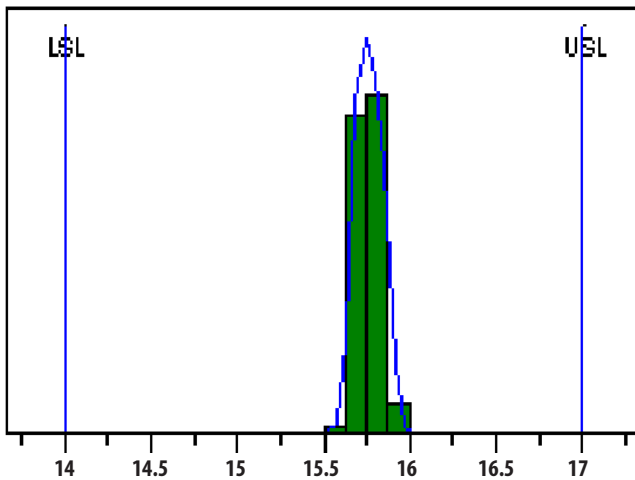

Figure 5. Gain

Notes :

1. Data sample size is 500 samples taken from 2 different wafers and 2 different lots. Future wafers allocated to this product may have nominal values anywhere between the upper and lower limits
2. Measurements are made on production test board which represents a trade-off between optimal Gain, NF, OIP3 and OP1dB. Circuit losses have been de-embedded from actual measurements.

MGA-53589 Typical Scatter Parameters

$T_c=25^{\circ}\text{C}$, $V_d=5.0\text{V}$, $I_d=55\text{mA}$, $Z_0=50\Omega$

Freq	S11	S11	S11	S21	S21	S21	S12,	S12	S12	S22	S22	S22
GHz	Mag	Ang	dB	Mag	Ang	dB	Mag	Ang	dB	Mag	Ang	dB
0.05	0.82	-41.80	-1.73	21.30	160.00	26.57	0.04	57.90	-27.74	0.71	-36.10	-3.02
0.1	0.64	-72.10	-3.92	17.10	146.00	24.66	0.06	37.60	-24.18	0.55	-67.80	-5.19
0.2	0.44	-108.00	-7.15	12.20	139.00	21.73	0.07	17.70	-22.57	0.35	-107.00	-9.17
0.3	0.36	-129.00	-8.85	10.30	136.00	20.26	0.08	8.18	-22.19	0.26	-133.00	-11.73
0.4	0.33	-143.00	-9.74	9.42	133.00	19.48	0.08	1.85	-22.04	0.22	-156.00	-13.31
0.5	0.31	-154.00	-10.26	8.93	130.00	19.02	0.08	-2.95	-21.98	0.19	-175.00	-14.29
0.6	0.30	-162.00	-10.54	8.60	125.00	18.69	0.08	-7.04	-21.94	0.18	168.00	-14.89
0.7	0.29	-169.00	-10.75	8.36	121.00	18.44	0.08	-10.60	-21.92	0.17	152.00	-15.19
0.8	0.29	-175.00	-10.87	8.16	116.00	18.23	0.08	-14.00	-21.91	0.17	138.00	-15.34
0.9	0.28	180.00	-10.96	7.98	110.00	18.04	0.08	-17.20	-21.89	0.17	125.00	-15.34
1	0.28	175.00	-11.00	7.81	105.00	17.85	0.08	-20.30	-21.88	0.17	113.00	-15.29
1.1	0.28	171.00	-11.00	7.65	99.20	17.67	0.08	-23.40	-21.89	0.18	101.00	-15.14
1.2	0.28	167.00	-10.96	7.49	93.60	17.49	0.08	-26.20	-21.91	0.18	91.00	-14.99
1.3	0.28	164.00	-10.93	7.33	88.00	17.30	0.08	-29.00	-21.91	0.18	81.10	-14.85
1.4	0.29	160.00	-10.84	7.18	82.20	17.12	0.08	-31.80	-21.92	0.18	71.90	-14.70
1.5	0.29	157.00	-10.75	7.02	76.50	16.93	0.08	-34.60	-21.95	0.19	63.10	-14.52
1.6	0.29	154.00	-10.66	6.87	70.90	16.74	0.08	-37.30	-21.96	0.19	54.60	-14.38
1.7	0.30	151.00	-10.54	6.73	65.00	16.56	0.08	-40.10	-21.96	0.20	46.50	-14.20
1.8	0.30	148.00	-10.40	6.57	59.30	16.35	0.08	-42.80	-21.97	0.20	38.80	-14.07
1.9	0.31	144.00	-10.29	6.42	53.70	16.15	0.08	-45.30	-22.01	0.20	31.30	-13.94
2	0.31	141.00	-10.12	6.27	48.00	15.95	0.08	-47.90	-22.04	0.20	24.10	-13.85
2.1	0.32	138.00	-9.95	6.11	42.30	15.72	0.08	-50.50	-22.05	0.21	17.10	-13.76
2.2	0.32	135.00	-9.79	5.95	36.70	15.49	0.08	-53.20	-22.08	0.21	10.20	-13.68
2.3	0.33	132.00	-9.63	5.81	31.20	15.28	0.08	-55.50	-22.10	0.21	3.64	-13.60
2.4	0.34	128.00	-9.45	5.65	25.70	15.04	0.08	-58.10	-22.11	0.21	-2.82	-13.56
2.5	0.35	125.00	-9.24	5.49	20.10	14.79	0.08	-60.80	-22.17	0.21	-9.11	-13.51
3	0.38	108.00	-8.36	4.77	-6.22	13.57	0.08	-72.30	-22.33	0.21	-38.50	-13.56
3.5	0.42	90.30	-7.51	4.11	-31.70	12.28	0.08	-83.30	-22.34	0.20	-65.20	-13.98
4	0.46	72.00	-6.76	3.53	-56.20	10.96	0.08	-95.10	-22.35	0.18	-89.70	-14.70
4.5	0.50	53.80	-6.09	3.05	-78.80	9.69	0.08	-107.00	-22.19	0.16	-112.00	-15.86
5	0.53	35.50	-5.48	2.64	-101.00	8.43	0.08	-118.00	-21.92	0.13	-133.00	-17.46
5.5	0.57	17.50	-4.93	2.30	-122.00	7.23	0.08	-129.00	-21.78	0.10	-151.00	-19.74
6	0.60	-0.32	-4.39	2.02	-143.00	6.11	0.09	-143.00	-21.29	0.07	-165.00	-23.41
6.5	0.64	-17.90	-3.92	1.78	-163.00	5.01	0.09	-157.00	-20.72	0.03	-165.00	-30.23
7	0.67	-35.40	-3.47	1.58	177.00	3.97	0.10	-172.00	-20.32	0.03	-81.50	-31.70
7.5	0.70	-52.60	-3.05	1.41	157.00	2.98	0.10	170.00	-20.26	0.07	-71.00	-23.17
8	0.73	-69.50	-2.70	1.25	137.00	1.94	0.10	155.00	-20.05	0.12	-81.60	-18.42
8.5	0.76	-86.20	-2.41	1.12	118.00	0.98	0.11	140.00	-19.25	0.17	-95.60	-15.24
9	0.78	-102.00	-2.18	1.00	98.40	-0.03	0.11	122.00	-19.49	0.23	-110.00	-12.84
9.5	0.79	-118.00	-2.04	0.88	79.70	-1.09	0.11	104.00	-19.09	0.28	-125.00	-11.00
10	0.80	-133.00	-1.96	0.79	60.80	-2.09	0.11	83.60	-19.09	0.34	-140.00	-9.50

Circuit description (for optimum OIP3)

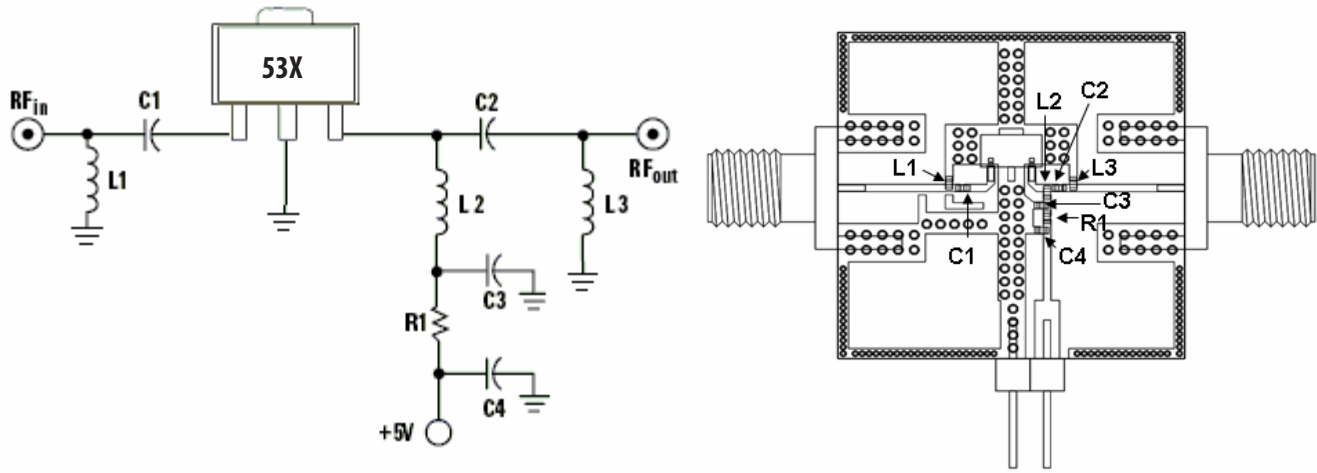

Bill of Materials

Circuit Symbol	Size	Description					
		For 0.9GHz [1]		For 1.9GHz [2]		For 2.4GHz [3]	
L1	0402	22nH	Toko	4.3nH	Coilcraft	12nH	Toko
C1	0402	8.2pF	Kyocera	1.5pF	Murata	3.3pF	Murata
L2	0402	47nH	Toko	3.9nH	Toko	68nH	Toko
C2	0402	8.2pF	Kyocera	3.0pF	Kyocera	6.8pF	Murata
L3	0402	39nH	Toko	NA	Not in use	4.7nH	Coilcraft
C3	0402	150pF	Murata	150pF	Murata	100pF	Murata
C4	0402	0.1uF	Murata	0.1uF	Murata	0.1uF	Murata
R1	0402	0 R	KOA	0 R	KOA	0 R	KOA

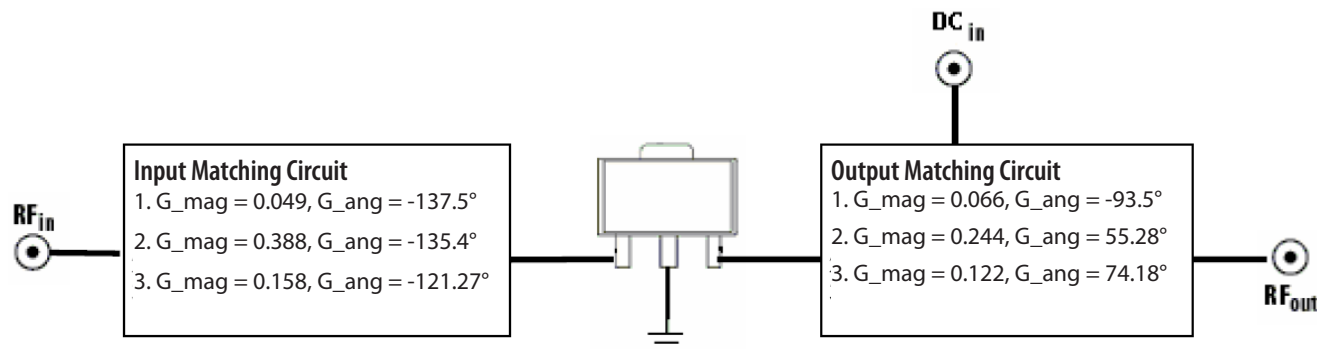
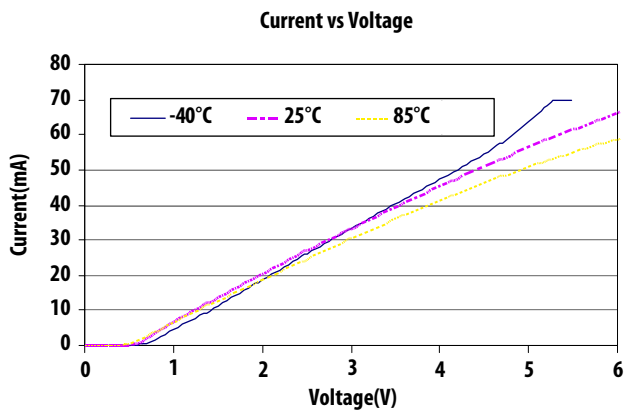
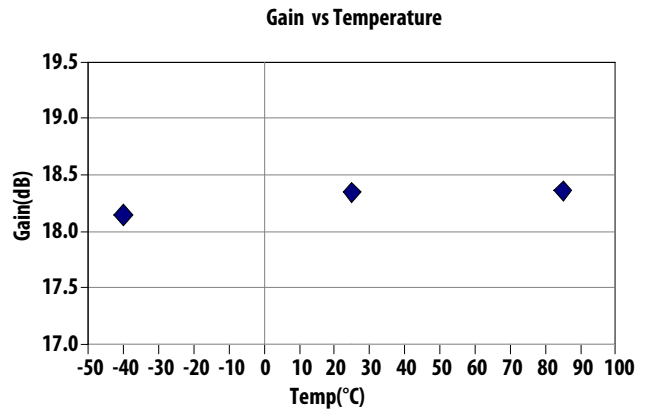
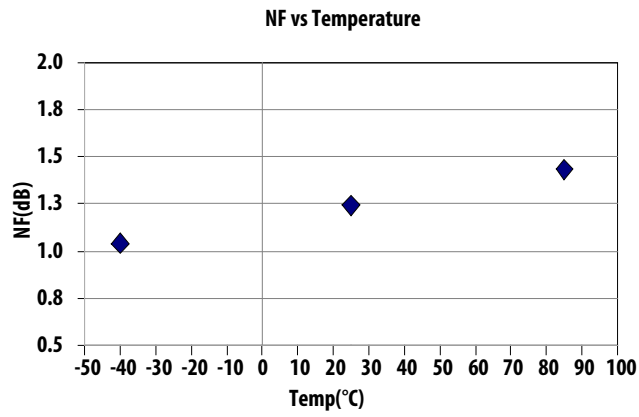
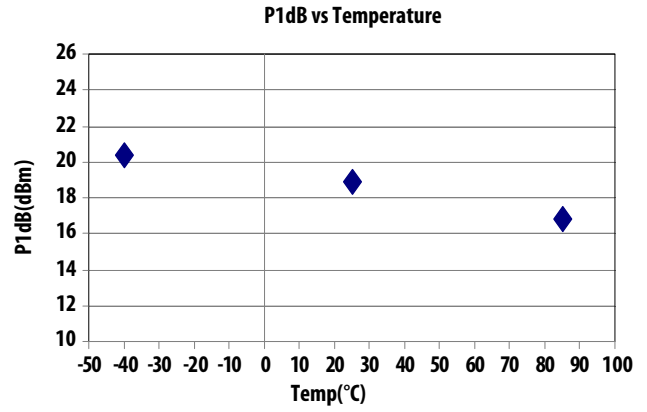
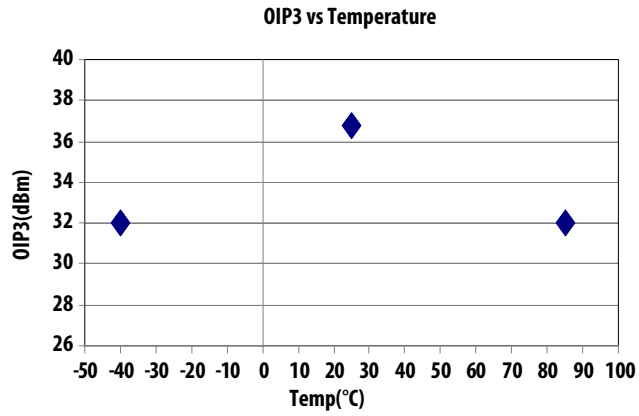

Figure 6. Demoboard and application circuit components table for Optimum OIP3

To bias the MGA-53589, a +5V supply is connected to the output pin thru an inductor labeled as L2; which isolates the inband signal from the DC supply as shown in Figure 6. Capacitor C3 serves as an RF bypass for inband signals while C4 helps to eliminate out the band low frequency signals. An optional R1 may be added to de-Q any resonance created between C3 and C4. Typical values range from 2.2Ω to 10Ω. A DC blocking capacitor C2, is used

at the output of the MMIC to isolate the supply voltage from succeeding circuits. L3 can be added to improve the circuits ESD as well as providing a better filtering output response. On its input, the C1 acts as a DC blocking capacitor (to isolate supply voltage from previous circuits) as well as with L1, creates a filter response that remove low frequencies signals.

Application Circuit : 900MHz (for optimum OIP3)



Application Circuit : 1900MHz (for optimum OIP3)

OIP3 vs Temperature

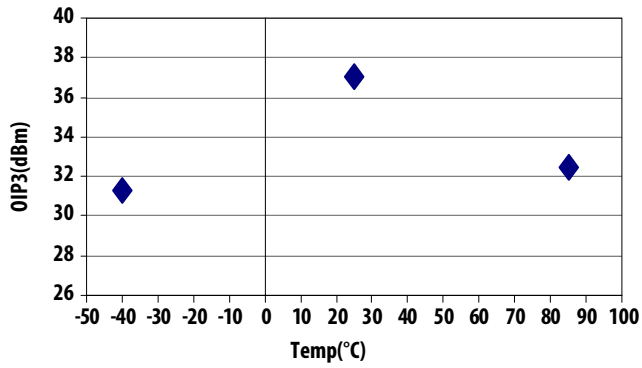

P1dB vs Temperature

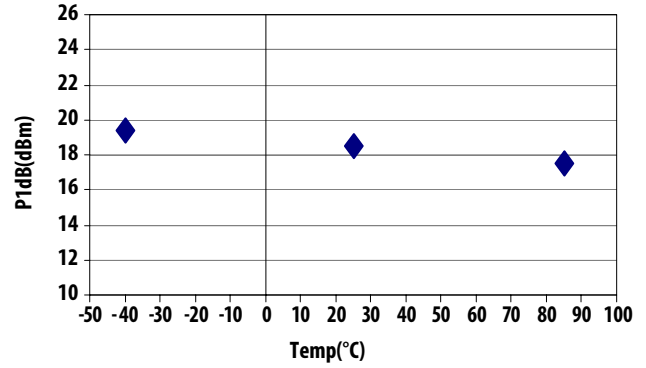

NF vs Temperature

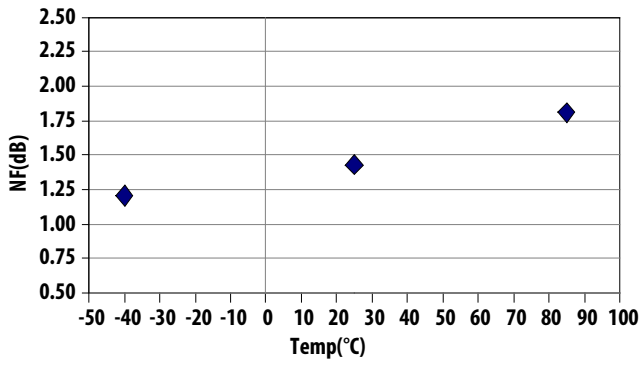

Gain vs Temperature

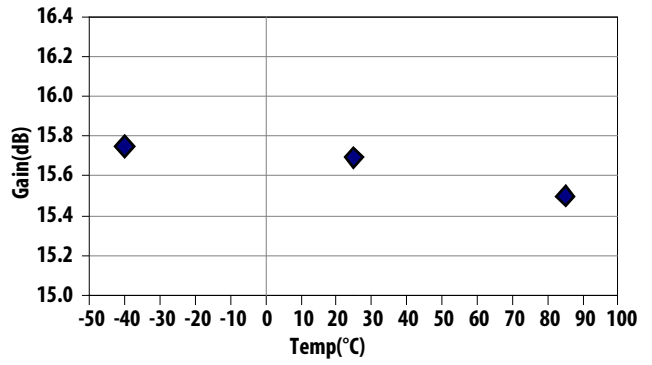

Current vs Voltage

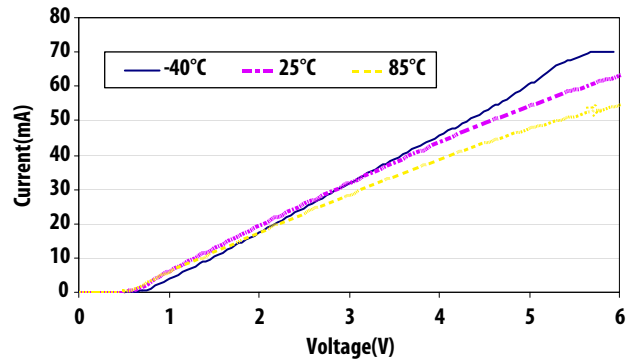

Application Circuit : 2400MHz (for optimum OIP3)

OIP3 vs Temperature

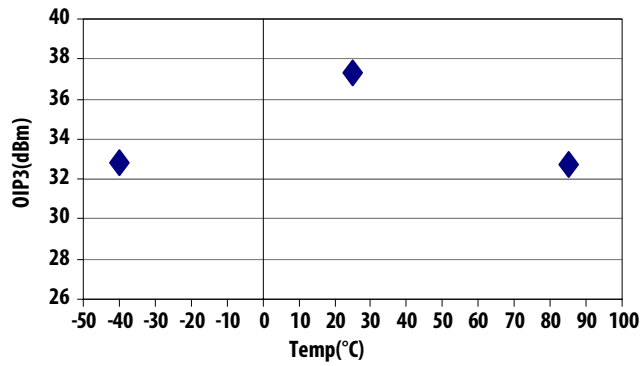

P1dB vs Temperature

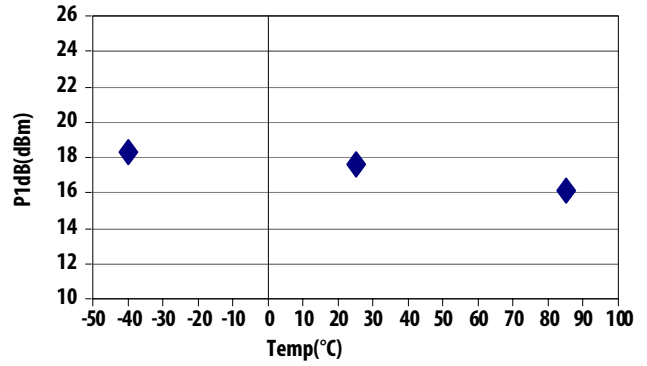

NF vs Temperature

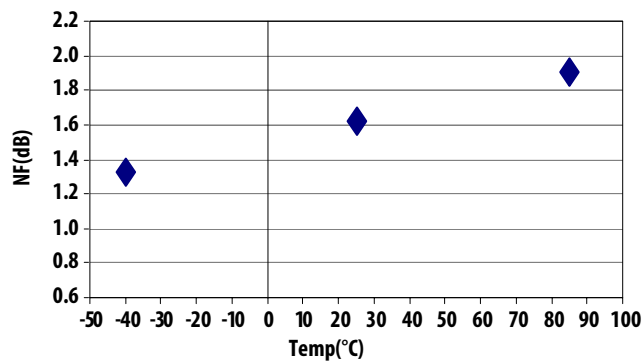

Gain vs Temperature

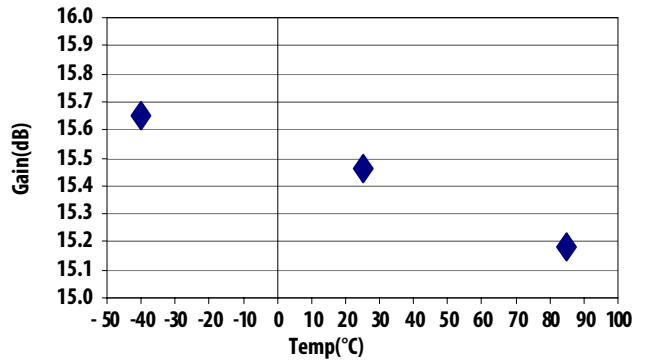

Current vs Voltage

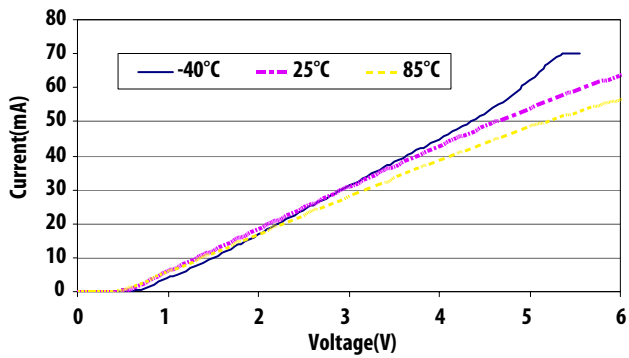

Circuit description (for Max OIP3)

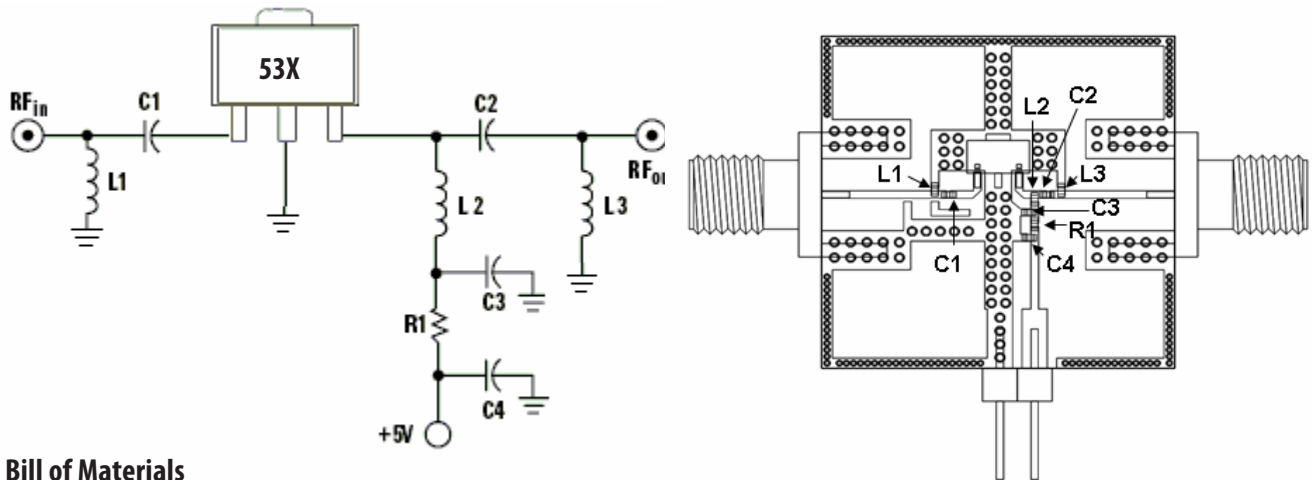

Bill of Materials

Circuit Symbol	Size	Description			
		For 0.9GHz [4]		For 1.9GHz [5]	
L1	0402	27nH	Toko	12nH	Toko
C1	0402	10pF	Kyocera	3.3pF	Murata
L2	0402	33nH	Toko	4.7nH	Toko
C2	0402	5.1pF	Murata	1.8pF	Kyocera
L3	0402	NA	Not in use	12nH	Toko
C3	0402	150pF	Murata	150pF	Murata
C4	0402	0.1uF	Murata	0.1uF	Murata
R1	0402	0ohm	Koa	0ohm	Koa

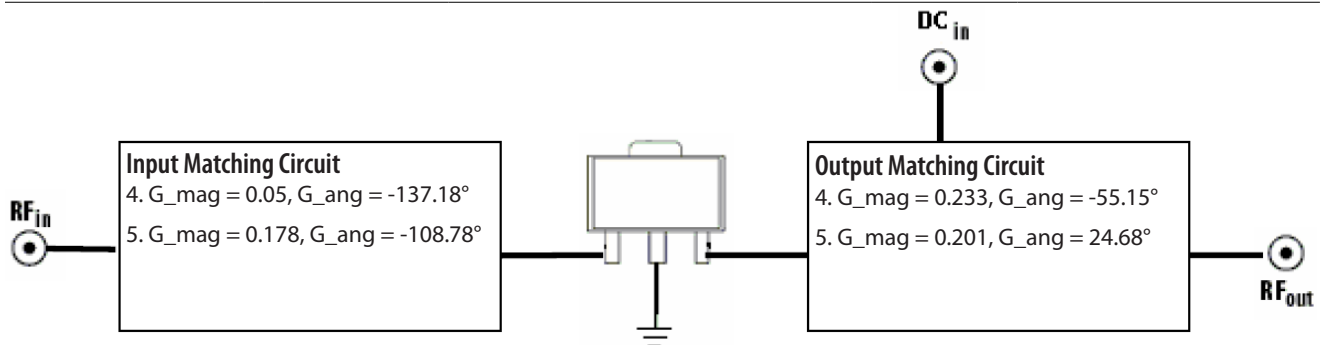
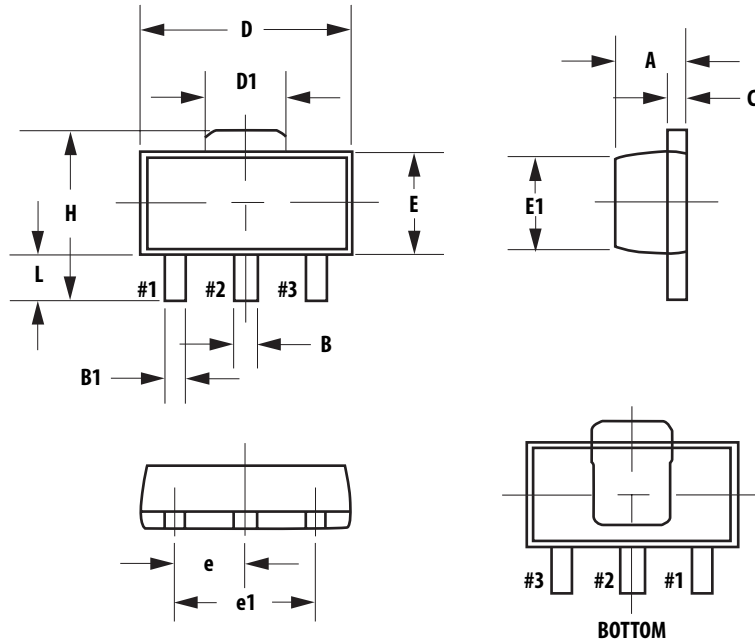

Figure 7. Demoboard and application circuit components table for max OIP3

Parameters	Tested at 25°C on Max OIP3 tuned Demoboard		Unit of measurement
	900MHz	1900MHz	
OIP3	40.9	39.6	dBm
NF	1.26	1.47	dB
Gain	17.5	15.9	dB
P1dB	18.6	18.4	dBm
PAE	25.0	27.0	%
RLin	-15.3	-13.3	dB
RLout	-12.1	-17.1	dB
Isolation	-22.2	-22.2	dB

Package Dimensions



Dimensions are in mm

COMMON						
SYMBOL	DIMENSIONS Millimeters			DIMENSIONS Inches		
	MIN.	NOM.	MAX.	MIN.	NOM.	MAX.
A	1.40	1.50	1.60	0.055	0.059	0.063
B	0.44	0.50	0.56	0.017	0.0195	0.022
B1	0.36	0.42	0.48	0.014	0.0165	0.019
C	0.35	0.40	0.44	0.014	0.016	0.017
D	4.40	4.50	4.60	0.173	0.177	0.181
D1	1.62	1.73	1.83	0.064	0.068	0.072
E	2.30	2.50	2.60	0.090	0.096	0.102
E1	2.13	2.20	2.29	0.084	0.087	0.090
e	1.50 BSC	1.50 BSC	1.50 BSC	0.059 BSC	0.059 BSC	0.059 BSC
e1	3.00 BSC	3.00 BSC	3.00 BSC	0.118 BSC	0.188 BSC	0.188 BSC
H	3.95	4.10	4.25	0.155	0.161	0.167
L	0.90	1.10	1.20	0.035	0.038	0.047

Notes:

1. Dimensioning and tolerancing per ANSI.Y14.5M-1982
2. Controlling dimension: Millimeter conversions to inches are not necessarily exact
3. Dimension B1, 2 places.

Device Orientation

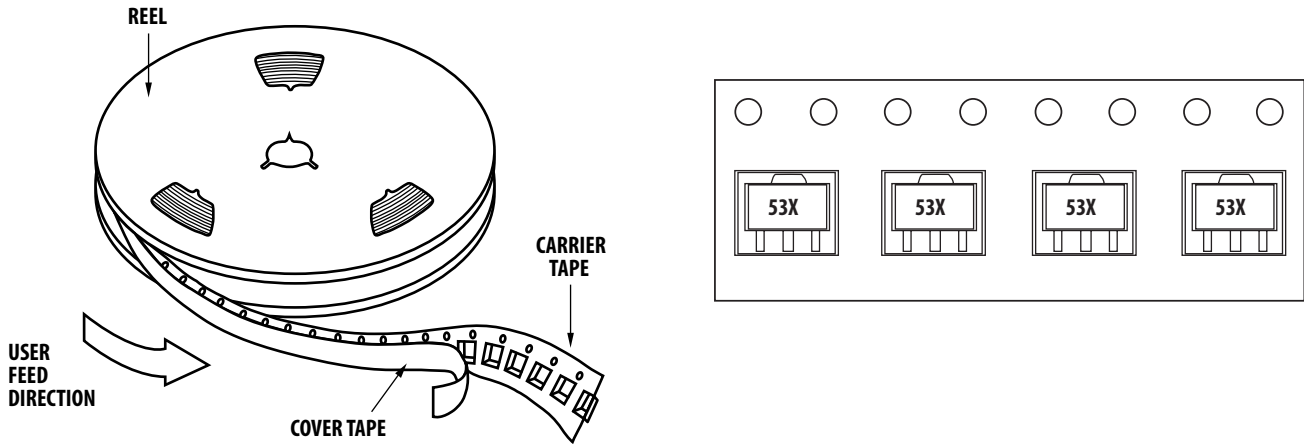

Tape Dimensions

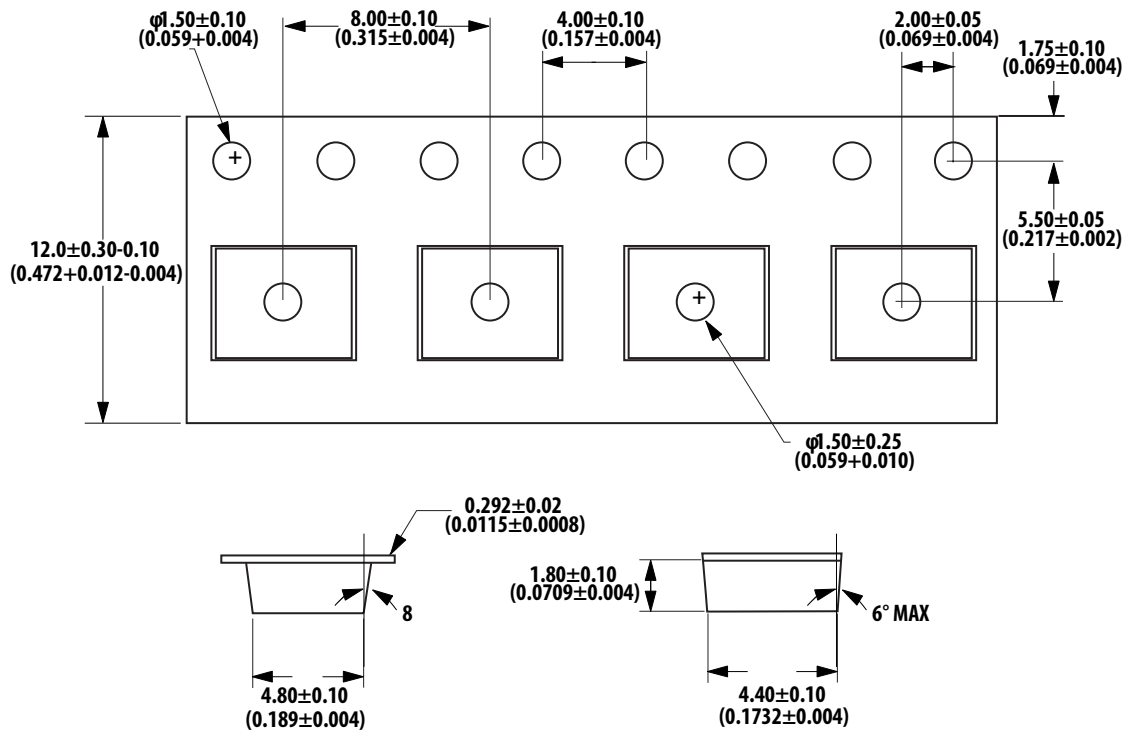

Dimensions in mm (inches)

For product information and a complete list of distributors, please go to our web site: www.avagotech.com

Avago, Avago Technologies, and the A logo are trademarks of Avago Technologies Limited in the United States and other countries. Data subject to change. Copyright © 2008 Avago Technologies Limited. All rights reserved. AV02-1273EN - May 28, 2008

AVAGO
TECHNOLOGIES